

Item No.	No. Required:	Material:	Description:	Revisions:					
				Sym.	Description:	Date:	DE	MFG	QA
*01	1	See Below	Container						
*02	1	See Below	Plug						

APPROVAL:

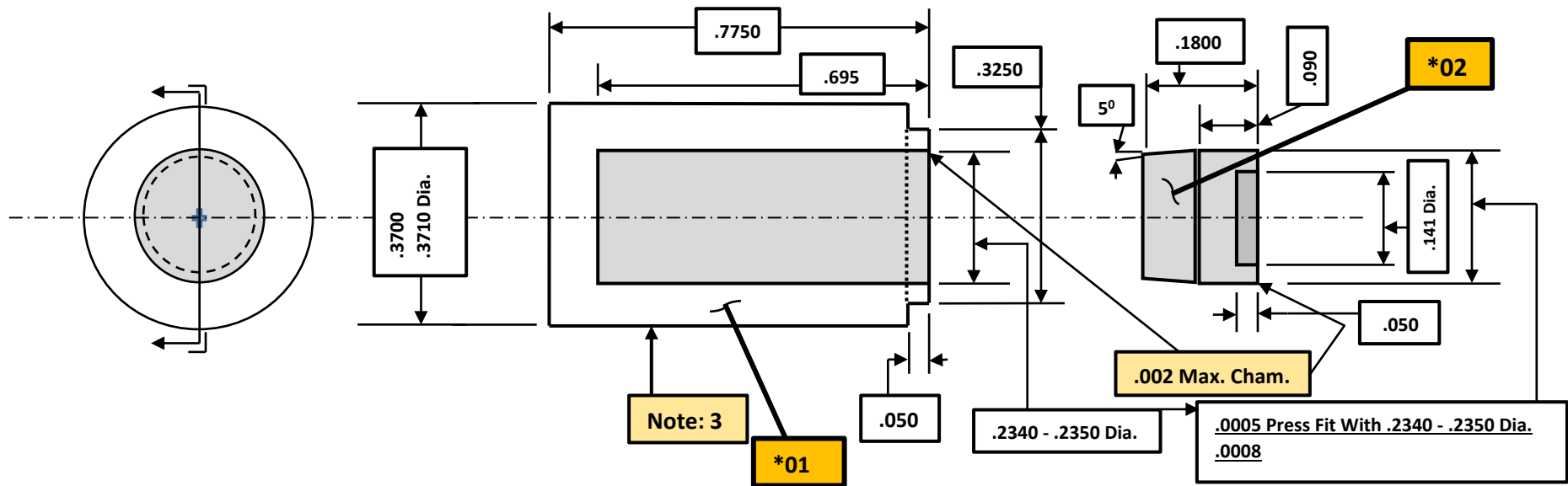

ALL SURFACES 32 FINISH.

Dimensions Are In: Inches. Millimeters.

Notes: 1. Break All Corners .010 - .020 Unless Otherwise Specified.
 2. TIG Weld. (Minimum 0.050 Weld Penetration).
 3. Electro-etch, Engrave, or Imprint Identification Marking.
 No More Than .005 Deep On Surface Indicated.

QA	APPROVAL:	EFJ	9/2/86
MFG			
DE			

FRONTIER TECHNOLOGY CORPORATION
 Xenia, Ohio. U.S.A.

Unless Otherwise Specified, Tolerances.
 Decimals: .XX _ .XXX = ± .005 .XXXX Basic. Angles ± 30°
 Material: 304 L Stainless Steel Per. ASTM A276 or A479

Drawn:	EFJ	9/2/86
Signature:		Date:

Standard Neutron Source Model 100SNS Capsule	Scale 4X Sheet 1 of 1	Drawing No. A10100-PA04	Rev. 0
---	--------------------------	----------------------------	--------