

Item No.	No. Required:	Material:	Description:
*01	1	See Below	Container
*02	1	See Below	Plug

Revisions:						Approval:			
Sym.	Description	Date:	DE	MFG	QA	MS			

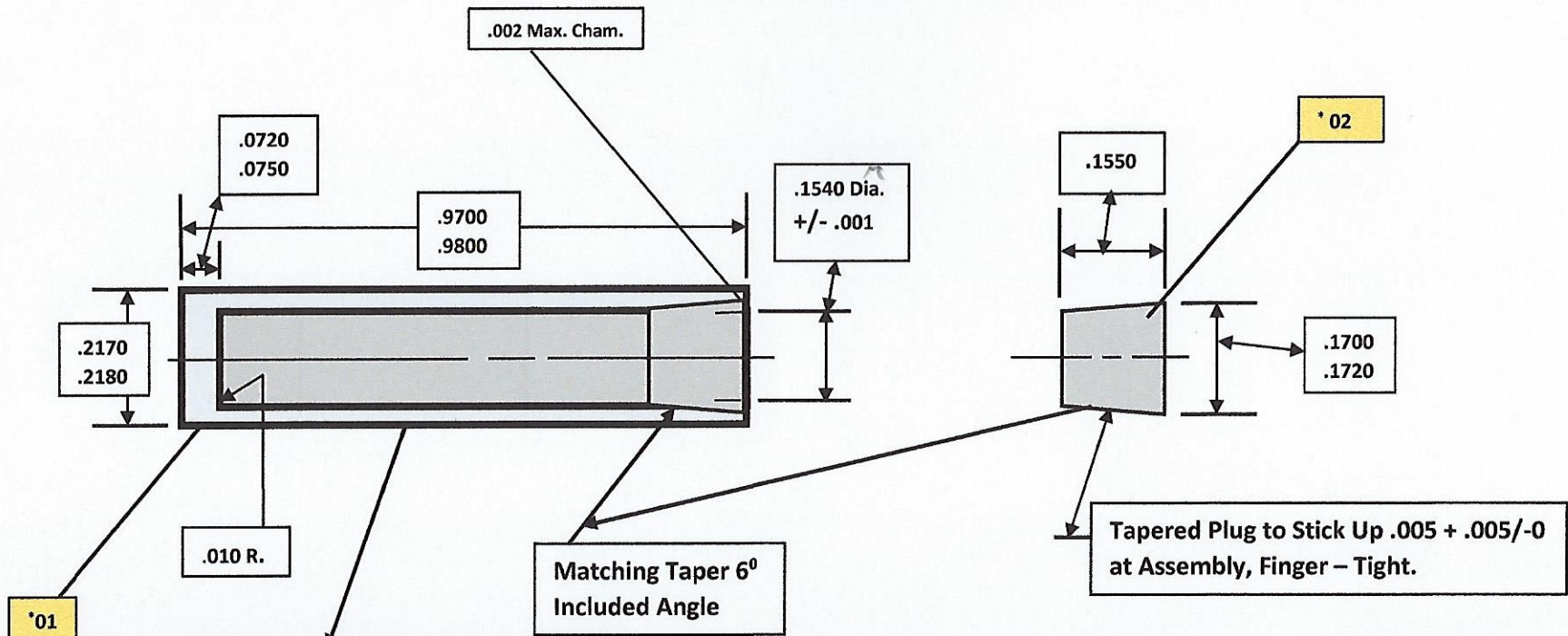

Electro etch, Engrave or Imprint Identification Marking
No More than .002 Deep on Surfaces Indicated.

Dimensions are in: X Inches Millimeters

Ref. SR-CF-1X Series

Notes: 1. Break All Corners .010 - .020 unless otherwise specified.
2. Press Plug Flush with Container Top, TIG Weld. (Minimum 0.030 Weld Penetration, Measured Along Joint).

FRONTIER TECHNOLOGY CORPORATION
XENIA, OHIO, U.S.A.

Unless Otherwise Specified Tolerances: .XX = ± / .XXX = ± .005 / .XXXX Basic All Surfaces 32 Finish.	MS	APPROVAL	EFJ	9-2-86
	QA		HC	
	MFG			
	DE			
Material: Zircaloy -2 Per. ASTM B351	Drawn		EFJ	9-2-86
	Signature:		Date:	

STANDARD NEUTRON SOURCE
MODEL Z10
Scale 4 X

DWG. NO.
A10010-ZA00
Rev. 0
Code Ident. No. SA10010
Sheet 1 of 1