

Item No.	Quantity	Material	Description
1	1	See Below	Container
2	1	See Below	Plug

Revisions:						APPROVAL:
Sym.	Description	Date	DE	MFG	QA	

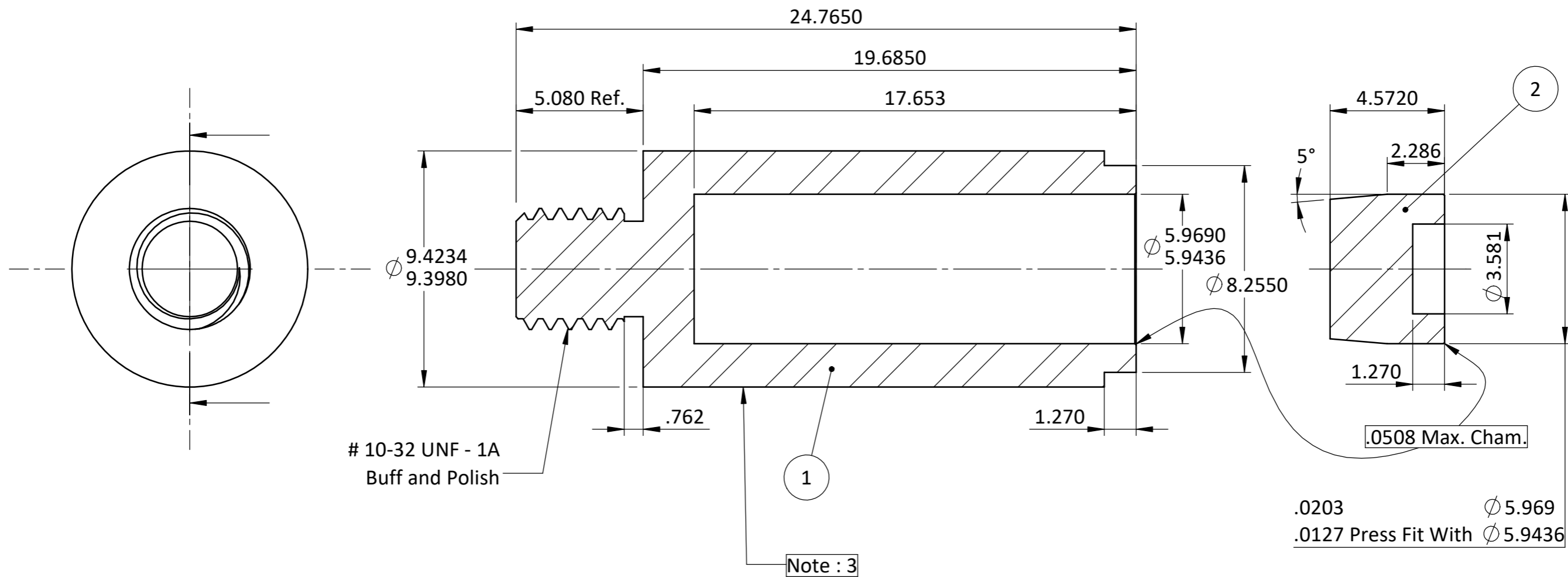

All Surfaces 32 Finish.

Dimensions Are In: Inches. Millimeters

Notes: 1. Break All Corners .254 - .508 Unless Otherwise Specified.
 2. TIG Weld. (Minimum 1.27 Weld Penetration).
 3. Electro-etch, Engrave, or Imprint Identification Marking. No More Than .127 Deep On Surface Indicated.

Unless Otherwise Specified, Tolerances.
 Decimals: Fractions:
 .xx_ .xxx = ± .127 .xxxx Basic. Angles ± 30°
 Material: 304 L Stainless Steel Per. ASTM A276 or A479

QA	APPROVAL.	EFJ	9/2/86
MFG			
DE			
Drawn:		EFJ	9/2/86
Signature:			Date:

FRONTIER TECHNOLOGY CORPORATION
 Xenia, Ohio, U.S.A.

TITLE:	Scale:	Drawing No.
Standard Neutron Source Model 100S Capsule	2:1	A10100-PA02
Sheet 1 of 1	Code Ident. No.	Rev. 0